



Fire Protection Sprinkler Service Gauge

Description

The Siemens Fire Protection Sprinkler Service Gauge is Underwriters Laboratory listed and Factory Mutual approved for fire protection sprinkler service. It has a 0 to 300 psi (0 to 2000 kPa) pressure range and is typically used on “wet” systems where water is available to the sprinkler heads.

It provides a triple scale dial plate (bar, kPa, and psi) to support use in multiple markets. A patented pointer damping technology provides unequalled shock and vibration resistance to extend gauge life. The large 3-1/2-inch diameter gauge is easy to read.

An optional shut-off ball valve accessory is available to simplify future gauge changeouts.

Part Numbers



**Part No: 142-801
Sprinkler Service Gauge**



**Part No: 142-851
Shut-off Ball Valve**



Appearance when units
are installed together

Features

- Underwriters Laboratory listed and Factor Mutual (FM) approved.
- Triple scale dial plate to provide readings in psi, kPa or bar.
- Corrosion-resistant and rugged ABS case.
- Heat-resistant polycarbonate push-in window.
- PowerFlex™ movement provides superior shock and vibration resistance.
- True Zero™ indication reduces the potential risk of installing a damaged gauge.
- Standard 1/4-inch NPT threaded connection fits most applications.

Specifications

142-801 Sprinkler Service Gauge

Pressure Range:	0 to 300 psi (0 to 2068 kPa) for “wet” systems with water to sprinkler heads.
Scales on Dial Plate:	0 to 300 psi, 0 to 2000 kPa, 0 to 20 bar
Nominal Gauge Size and Indicator:	3-1/2-inch diameter with black aluminum pointer
Accuracy:	ASME B 40.100 Grade B ($\pm 3-2-3\%$ of span)
Operating Temperature:	-40°F to 150°F (-40°C to 65°C)
Connection:	1/4-inch NPT brass lower connection
Construction:	ABS case with polycarbonate window. Shock and vibration resistant.

142-851 Gauge Shut-off Ball Valve

Connection:	1/4-inch NPT nickel-plated brass
Actuation:	Quarter turn valve with black nylon handle. Blow-out proof stem.
Pressure Range:	Up to 450 psi (3100 kPa)
Operating Temperature Range:	-4°F to 200°F (-20°C to 93°C)
Construction:	Hard chrome-plated brass ball. PFE seat. Vitron green O-ring.

Dimensions

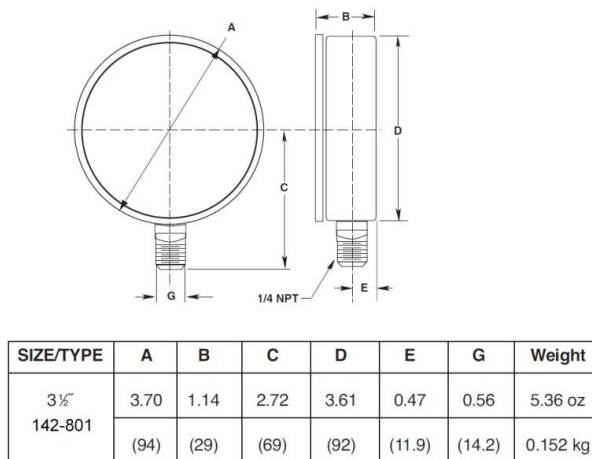

Figure 1. 142-801
Fire Protection Sprinkler Service Gauge.

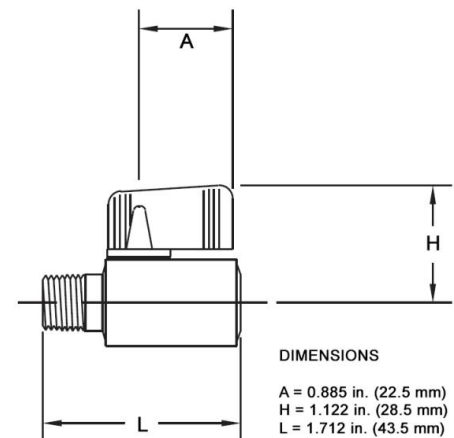

Figure 2. 142-851
Shut-off Ball Valve Accessory.

Information in this document is based on specifications believed correct at the time of publication. The right is reserved to make changes as design improvements are introduced. Product or company names mentioned herein may be the trademarks of their respective owners.
 © 2017 Siemens Industry, Inc.